

K63 ONE-CHIP AM RADIO

This project presents the building blocks of modern day mini-sized AM radio receivers as found in key-rings, watches & palm-sized radios. They are:

- the Tuned Radio Frequency (TRF) front end
- a single chip AM radio IC, and
- amplification of the audio signal into a speaker

All these components are presented on a single printed circuit board so you can build and experiment with your radio. We have built the Kit using standard passive components. Commercial products usually use surface mount components which results in very small sized radios.

AM radio broadcasts consist of a radio frequency (RF) signal generated at a specific frequency allocated to a particular station. On this RF signal is superimposed an audio frequency signal. The audio frequency is said to amplitude modulate the radio frequency carrier.

AM RF signals of all frequencies are present all around us. Our radio must be able to be 'find' the station we want from all the thousands of signals present. It has to be able to tune into the desired radio station and exclude all other signals. And it must be able to tune into weak signals just as easily as tune into strong signals. Let us introduce two technical terms to describe these requirements.

Sensitivity is the ability to pick up weak signals while keeping the background noise to a minimum. **Selectivity** is the ability of a radio to tune into a particular station and reject all other stations. For mini-radio users selectivity is usually the more important: teenagers listening to heavy metal, adults listening to the horse races, soap operas and the news. Most often the listener wants to be able to pick up all the local stations without any interference even though adjacent stations may be very close on the dial. Usually they are not much concerned with being able to detect distant AM signals say over 30 miles away.

1. The TRF Front End

This consists of two components, the ferrite aerial coil and the tuning capacitor. The important word is tuned. All the AM signals reaching the radio are very, very weak. Only that signal which matches the TRF frequency is magnified by resonance so that it stands out at a very much higher

level of signal strength.

This Kit uses a standard 60/160 AM Tuning Capacitor. It contains two film capacitors. Their capacitance changes as you turn the knob. We only use the 0 - 160pF capacitor for our radio. (The other 0 - 60pF capacitor is used in better quality AM radios that use regeneration on the aerial coil.) The centre pin is the common connection. The two screws on the back of the package are to trimmer capacitors associated with each capacitor. If you are unfamiliar with this item connect it to a capacitance meter and play with the main adjustment knob and the trimmer capacitors so you understand what is happening. In this radio the position of the trimmers does not matter.

The second component of the TRF is the coil & ferrite bar. We supply the coil prewound with 90 turns of 3 strand Litz wire. We got these coils from a commercial manufacturer of these coils who supplies exactly the same item to AM radio manufacturers. Litz wire consists of many strands of fine enamelled wire twisted together with cotton to add strength. Litz wire has a significantly lower resistance to RF than a single wire and is used in virtually all commercial coils.

The ferrite bar increases the inductance of the coil. The two components connected in parallel form a LC network. The Litz wire of the coil and the ferrite bar give the network a high Q, or Quality factor. This is critically important for the selectivity of the radio, the ability to tune into one radio station only and not be able to hear several others at the same time.

The coil winding & the ferrite bar acts as an efficient wire antenna. No additional external antenna is needed. The only disadvantage is that the tuned circuit is directional. Signal strength depends on the orientation of the bar with respect to the origin of the signal.

2. AM Radio ICMK484

It is important to realise that the radio IC does not create any sounds by itself. It can only take the RF signal provided from the TRF circuit, amplify it, separate the audio signal from the RF (called detection) and pass the audio signal on to be amplified. It has no selective or rejection components contained in it. (This is in contrast to superhetrodyne receivers.) The MK484 we use is a Japanese copy of the original ZN414. It contains an RF amplifier, active detector and automatic gain control (AGC to improve sensitivity) all in a 3-pin package. The input impedance is typically 4M ohm. It operates over a range of 150kHz to 3MHz. DC supply of 1.1V to 1.8V & 0.3mA current drain makes it ideal for battery operation. The output is typically 40 - 60 mV of audio signal. Optimal AGC is provided by R3 and C2 (see Figure 2). R3 (the AGC resistor) should be in the range 100R to 1.5K. A bandwidth of about 4kHz is achieved.

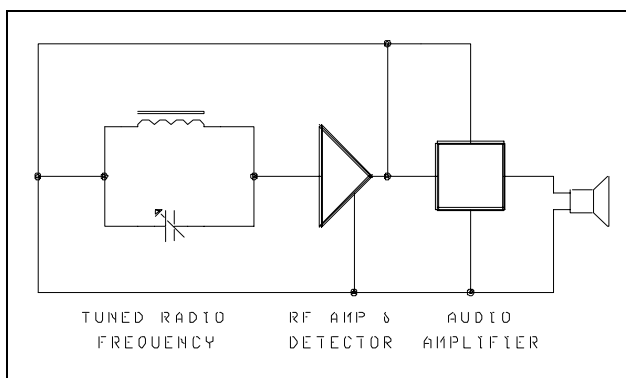

K63 ONE-CHIP AM RADIO

3. Audio Amplification

The audio signal output from the MK484 is too weak to drive a speaker directly. In our Kit the signal is fed into two stages of amplification and then into a speaker. These are standard designs. The first is a transistor Class A amplifier. The second is a Class AB amplifier. See DIY Kit 48 Introduction to Class AB Amplifiers for a description of how it works.

Our Design

Our circuit is shown below. You should be able to understand most of it from the above block descriptions. The two forward biased diodes D1 & D2 appear to short circuit the power supply to the MK484, but this IC only requires about 1.5V to operate and the combined forward drop of the 2 diodes is exactly right.

The tuning capacitor has been securely mounted on the PCB by 2 screws. We have provided an extension rod to fit onto the capacitor tuner so that a knob can be attached. The volume potentiometer is also mounted on the PCB. Mounting holes to tie down the aerial coil have also been provided. We aimed to provide the complete radio, excluding speaker, on a single PCB so that it was easy to experiment with. It can be modified to fit into a box.

Construction

Components may be added to the board in any order. But it is usually best to add the lowest height components first, the resistors and diodes. Make sure you get the diodes around the correct way. The black bar on the diode corresponds to the bar on the overlay.

All the BC548, BC558 and the MK484 come in a TO-92 package. Identify each one and put them in their correct positions as shown on the overlay.

Testing

We were surprised at the quality of the radio reception we got from this Kit. You can experiment with changing the number of turns on the coil to shift the TRF range.

If It Does Not Work. Check that the diodes are all in the correct way. Are the resistors in the right places. Check that the TO-92 packaged components are in their correct places and orientation.

COMPONENTS

Resistors:			
6R8	R9 R10	blue grey gold	2
100R	R6	brown black brown	1
1K	R3	brown black red	1
4K7	R1	yellow violet red	1
5K6	R7	green blue red	1
10K	R4	brown black orange	1
100K	R2	brown black orange	1
150K	R5	brown yellow orange	1
820K	R8	grey red orange	1
10K log pot	Piher		1
Spindle for pot			1
Capacitors:			
470p ceramic	C7		1
470nF monoblock	C1 C4 C5 C6		4
100nF monoblock	C2		1
100uF elcap	C3 C8		2
60/160 AM tuning cap			1
1N4148 diode	D1 D2 D3 D4		4
BC548			3
BC558			1
Screws for tuning cap			2
Brass extension			1
Screw for extension			1
MK484 AM radio IC			1
2 pole terminal block			2
Coil & ferrite bar set			1
3", 0.5 or 1W, 8 ohm speaker			1
Kit 63 PCB			1
Documentation			

